

**Khwaja Fareed University of Engineering &  
Information Technology, Rahim Yar Khan**



# **Tender Document**

**Tender No. Misc-050**

**Supply of Drawing Tables & Sitting Stools for Civil  
Engineering Department**

**at**

**Khwaja Fareed University of Engineering  
& Information Technology  
Rahim Yar Khan**

**TENDER DOCUMENT**

**TENDER No. Misc-050**

**Supply of Drawing Tables & Sitting Stools for Civil Engineering Department**

at

**Khwaja Fareed University of Engineering and Information Technology**

TENDER PRICE Rs. 1000/-

Last date of submission: \_\_\_\_\_

FOR OFFICE USE ONLY

Serial No. \_\_\_\_\_

Sold to: M/S \_\_\_\_\_

Date of Sale \_\_\_\_\_

Bank Challan No. \_\_\_\_\_

Date \_\_\_\_\_

## **1. Overview**

Khwaja Fareed University of Engineering & Information Technology, Rahim Yar Khan intends to purchase “**Supply of Drawing Tables & Sitting Stools for Civil Engineering Department**” as provided at **Annex ‘A’**. The supplier will be responsible for Supply, delivery, commissioning of all specified items, wherever required, at the Khwaja Fareed University of Engineering & Information Technology, Rahim Yar Khan. This document provides complete instructions for bidders intending to participate in this Tender.

## **2. Instructions for Bidders**

**2.1.** Response to the Tender (Bid) should be submitted in one part which shall include two separately sealed envelopes of **Technical Proposal** and **Financial Proposal** before **01:00 PM** on **12-09-2017**. Technical Proposals will be opened on same day at **01:30 PM** in the presence of representatives of responding bidders, if any, and Financial Proposals will be opened after completion of technical evaluation. The exact time and place for opening of financial proposals will be informed to technically qualified bidders.

**2.2.** Responding bidder shall deliver two sealed copies of the bid. Each copy being physically separate, bound, sealed and labeled. Proposals shall be delivered at the address given below.

**Director Procurement**

**Khwaja Fareed University of Engineering & Information Technology  
Abu Dhabi Road, Rahim Yar Khan.**

**Tel. # 068-5882420**

**2.3.** Any queries regarding this proposal should be directed to the designated Technical Contact Person listed below.

**Engr. Waqar Ahmed, Tel. # 0334-7309073**

**2.4.** All bids must be submitted by filling the **Annex ‘B’**. Same should be enclosed in the financial proposal. Bidder must use the same numbers and labels used in this Request for Proposal.

**2.5.** The original Tender Document duly signed and officially sealed by the bidder must be submitted in whole with the proposals. Any conditional, ambiguous, incomplete, supplementary or revised offer after the opening of tender shall not be entertained.

### **3. Technical Proposal Format**

Bidders are required to include the following documents/information in their technical proposals in the order given below:

- i. The Name and Address
- ii. Profile of company (Including Financial Profile)
- iii. List of Previous/Current customers of related designing, composing and printing of prospectus, with contact person and telephone/fax numbers.
- iv. Detailed product design information
- v. Copy of National Tax Registration Certificate
- vi. Copy of Sales Tax Registration Certificate
- vii. Bank letter of financial standing
- viii. An affidavit on Rs 100/- Stamp Paper that currently they are not black listed or debarred by any Government/Semi-Government Department to participate in bidding and to supply equipment. Failure to submit such affidavit may lead to disqualification.
- ix. Any additional information the bidder may like to furnish e.g. repair/maintenance other concerned facility
- x. Detailed item specifications matched corresponding to the BOQ as given at **Annex 'A'**
- xi. Detailed project implementation schedule/Completion Schedule which includes the delivery of items mentioned in the BOQ
- xii. Signed and stamped Tender document
- xiii. Bank Draft of the Earnest Money

### **4. Financial Proposal Format**

Financial Proposal must include the following in the order given below:

- i. Equipment prices duly entered on the form in the attached BOQ
- ii. Validity period of the quoted price
- iii. Any other Terms and Conditions

## 5. Terms & Conditions

- 5.1. This invitation for bids is open to all national original Manufacturers/ Distributors/Agents in Pakistan for Supply of Tools, Carpentering, Plumbing and Electric Material.
- 5.2. All prices should be quoted in Pak Rupees and inclusive of all Government Taxes & Levies.
- 5.3. A bank draft equal to 2% of the estimated cost should accompany the Tender as **Earnest Money** drawn in favor of **KFUEIT Rahim Yar Khan**. The Tender shall not be considered without Earnest Money. Bank guarantee will not be accepted. Bank draft for Earnest Money should be placed with the Technical proposal.
- 5.4. Earnest Money for bidders not selected will be returned a minimum of two weeks after announcement of award and returned to successful bidder after signing the contract. If the selected bidder fails to sign the contract within stipulated time, Earnest Money will be forfeited.
- 5.5. A Bank draft of 5% of the total amount as **Performance Guarantee** will be provided by the supplier in favor of KFUEIT, Rahim Yar Khan within 10 days after signing of the contract on judicial stamp paper of the value PKR. 1200/-which shall remain valid for 12 months beyond delivery period. This performance guarantee will be released after the completion of warranty/guarantee period, along with the satisfactory completion report which will be intimated to the Seller and the Director Procurement KFUEIT, Rahim Yar Khan for their onward issuance of No Objection Certificate (NOC) for the release of performance guarantee.
- 5.6. KFUEIT Rahim Yar Khan reserves the right to accept / reject any or all proposals without assigning any reason thereof.
- 5.7. The quantity of an order may vary depending on the quoted prices and the allocated funds.
- 5.8. The decision of the KFUEIT procurement committee will be binding on all concerned and will in no case be challenged in any forum.
- 5.9. KFUEIT Rahim Yar Khan reserves the right to modify the conditions / specifications of the Tender Document with written intimation to all the participants who have purchased the Tender Document.
- 5.10. Delivery period will be 45 days from the date of issuance of purchase order/supply order.

- 5.11.** Delivery shall be completed according to the agreed upon schedule.
- 5.12.** In case the selected bidder fails to execute the contract strictly in accordance with the terms and conditions laid down in the contract, the Performance Guarantee shall be forfeited.
- 5.13.** The University will get the item inspected at KFUEIT Rahim Yar Khan and reject the item, if not found according to the stated specifications.
- 5.14.** The University reserves the right to claim compensation for the losses caused by delay in the delivery of equipment.
- 5.15.** It is the sole responsibility of the bidder to comply with local, national and international laws.
- 5.16.** In case any supplies/material is found not in conformity with the specifications provided in the tender, either on account of inferior quality, defective workmanship, faulty design, faulty packing or is short supplied, or wrongly supplied, the supplier will replace the same free of charges or pay the full cost of replacement.
- 5.17.** All the proposals submitted will become the property of the University.
- 5.18.** All prices should be valid for at least 60 days. Withdrawal or any modification of the original offer within the validity period shall entitle the KFUEIT Rahim Yar Khan to forfeit the Earnest Money in favor of the KFUEIT Rahim Yar Khan and/or putting a ban on the future inquires or taking any other suitable action against the bidder.
- 5.19.** Delivery of the items will be free of charge at Khwaja Fareed University of Engineering & Information Technology, Rahim Yar Khan during the office hours with a copy of Delivery Challan.
- 5.20.** Items being ordered should be brand-new and according to order specification from the current production and covered under normal warranty/guarantee etc. as mentioned in the quote. Brochures mentioned and product details must be attached.

## **6. Tender Evaluation Criteria**

All bids shall be evaluated on technical and financial merit. The Company Evaluation Criteria is attached at **Annex 'C'** for reference. Technical evaluation process may include, but not limited to the consideration of the following with respect to the functional requirements given ahead:

- a. Technical specifications of proposed item
- b. Company Profile

- I. Age of the company
- II. Financial strength of the bidder

Financial Evaluation process will be based on the consideration of the quoted price.

**7. Undertaking**

On behalf of the company it is certified that we agree to the all the Instructions and Terms & Conditions given in this Tender Document

Name of bidder.....

Authorized person.....

Authorized signature.....

Stamp.....

Office Address.....

Tel No .....

Fax No .....

## Supply of Drawing Tables & Sitting Stools for Civil Engineering Department

<b>Sr. No</b>	<b>Item Name</b>	<b>Specifications/Minimum Requirements</b>	<b>Qty.</b>
1	Drawing Table	Made of well-seasoned sheshum wood top over hollow rectangular steel pipe sectional frame	50
2	Sitting Stool	Made of well-seasoned sheshum wood top over hollow rectangular steel pipe sectional frame	50



**Supply of Drawing Tables & Sitting Stools for Civil Engineering  
Department**

**(Bid Form)**

<b>Sr. No.</b>	<b>Item Name</b>	<b>Qty.</b>	<b>Rate/Unit</b>	<b>Total Price</b> (inclusive of all taxes, and Shipment charges)
01	<b>Drawing Table</b>	<b>50</b>		
02	<b>Sitting Stool</b>	<b>50</b>		
TOTAL: _____				
Total in Words: _____				

# Drawings



KHWAJA FAREED UNIVERSITY OF ENGINEERING & INFORMATION  
TECHNOLOGY, ABU DHABI ROAD, RAHIM YAR KHAN  
DEPARTMENT OF CIVIL ENGINEERING

Ref. No. KFUE&IT/CE/019  
Dated: August 16, 2017

## Annexure-I

Drawing Table (Not to scale)

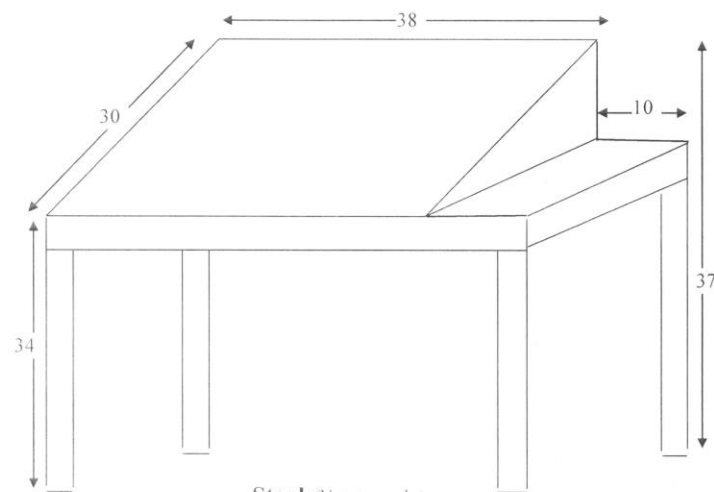

Stool (Not to scale)

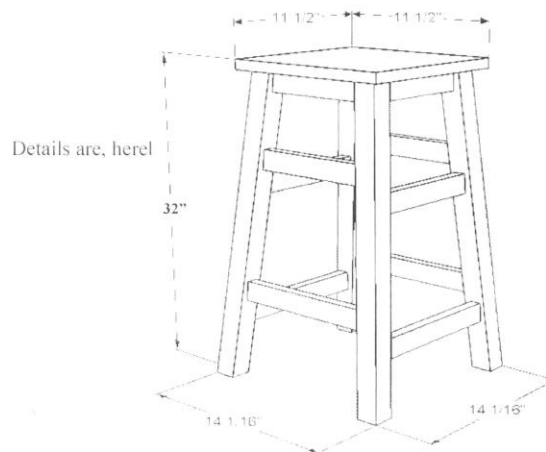

## Company Evaluation Criteria

### 1. Basic Evaluation

- i. Profile of company (Including Financial Profile)
- ii. List of Previous/Current customers of related Supplies, with contact person and telephone/fax numbers.
- iii. Detailed product design information
- iv. Copy of National Tax Registration Certificate
- v. Copy of Sales Tax Registration Certificate
- vi. Bank letter of financial standing
- vii. An affidavit on Rs 100/- Stamp Paper that currently they are not black listed or debarred by any Government/Semi-Government Department to participate in bidding and to supply equipment. Failure to submit such affidavit may lead to disqualification.
- viii. Detailed item specifications matched corresponding to the BOQ as given at **Annex 'A'**
- ix. Detailed project implementation schedule/Completion Schedule which includes the delivery of items mentioned in the BOQ
- x. Signed and stamped Tender document